



■ Features :

- AC input 180 ~ 264VAC
- AC input active surge current limiting
- High efficiency up to 90%
- Built-in active PFC function, PF>0.95
- Protections: Short circuit / Overload / Over voltage / Over temperature / Fan alarm
- Forced air cooling by built-in DC with fan speed control function
- Output voltage can be trimmed between 20~110% of the rated output voltage
- High power density 15.6W/inch³
- Current sharing up to 3 units
- Alarm signal output (relay contact and TTL signal)
- Built-in 12V/0.1A auxiliary output for remote control
- Built-in remote ON-OFF control
- Built-in remote sense function
- 5 years warranty



SPECIFICATION

MODEL	RSP-3000-12	RSP-3000-24	RSP-3000-48	
OUTPUT	DC VOLTAGE	12V	24V	48V
	RATED CURRENT	200A	125A	62.5A
	CURRENT RANGE	0 ~ 200A	0 ~ 125A	0 ~ 62.5A
	RATED POWER	2400W	3000W	3000W
	RIPPLE & NOISE (max.) Note.2	150mVp-p	150mVp-p	200mVp-p
	VOLTAGE ADJ. RANGE	10.8 ~ 13.2V	22 ~ 28V	43 ~ 56V
	VOLTAGE TOLERANCE Note.3	±1.0%	±1.0%	±1.0%
	LINE REGULATION	±0.5%	±0.5%	±0.5%
	LOAD REGULATION	±0.5%	±0.5%	±0.5%
	SETUP, RISE TIME	1000ms, 80ms at full load		
HOLD UP TIME (Typ.)	10ms at full load			
INPUT	VOLTAGE RANGE	180 ~ 264VAC 254 ~ 370VDC		
	FREQUENCY RANGE	47 ~ 63Hz		
	POWER FACTOR (Typ.)	0.95/230VAC at full load		
	EFFICIENCY (Typ.)	86%	89.5%	90.5%
	AC CURRENT (Typ.)	20A/180VAC 16A/230VAC		
	INRUSH CURRENT (Typ.)	60A/230VAC		
	LEAKAGE CURRENT	<2.0mA / 240VAC		
PROTECTION	OVERLOAD	100 ~ 112% rated output power User adjustable continuous constant current limiting or constant current limiting with delay shutdown after 5 seconds, re-power on to recover		
	OVER VOLTAGE	13.8 ~ 16.8V	28.8 ~ 33.6V	57.6 ~ 67.2V
	OVER TEMPERATURE	90°C ±5°C (12V), 110°C ±5°C (24V), 105°C ±5°C (48V) (TSW1: detect on heatsink of power transistor) 90°C ±5°C (12V), 85°C ±5°C (24V), 75°C ±5°C (48V) (TSW2: detect on heatsink of o/p diode) Protection type : Shut down o/p voltage, recovers automatically after temperature goes down		
FUNCTION	AUXILIARY POWER(AUX)	12V@0.1A(Only for Remote ON/OFF control)		
	REMOTE ON/OFF CONTROL	Please see the Function Manual		
	ALARM SIGNAL OUTPUT	Please see the Function Manual		
	OUTPUT VOLTAGE TRIM Note.5	2.4 ~ 13.2V	4.8 ~ 28V	9.6 ~ 56V
	CURRENT SHARING	Please see the Function Manual		
ENVIRONMENT	WORKING TEMP.	-20 ~ +70°C (Refer to "Derating Curve")		
	WORKING HUMIDITY	20~90% RH non-condensing		
	STORAGE TEMP., HUMIDITY	-40 ~ +85°C, 10 ~ 95% RH		
	TEMP. COEFFICIENT	±0.05%/°C (0 ~ 50°C)		
	VIBRATION	10 ~ 500Hz, 2G 10min./1cycle, 60min. each along X, Y, Z axes		
SAFETY & EMC (Note 4)	SAFETY STANDARDS	UL60950-1, TUV EN60950-1 approved		
	WITHSTAND VOLTAGE	I/P-O/P:3KVAC I/P-FG:2KVAC O/P-FG:0.5KVAC		
	ISOLATION RESISTANCE	I/P-O/P, I/P-FG, O/P-FG:100M Ohms / 500VDC / 25°C / 70% RH		
	EMC EMISSION	Compliance to EN55022 (CISPR22) Class B, EN61000-3-2,-3		
	EMC IMMUNITY	Compliance to EN61000-4-2,3,4,5,6,8,11, EN55024, light industry level, criteria A		
OTHERS	MTBF	104.5K hrs min. MIL-HDBK-217F (25°C)		
	DIMENSION	278*177.8*63.5mm (L*W*H)		
	PACKING	4Kg; 4pcs/16Kg/1.89CUFT		
NOTE	<ol style="list-style-type: none"> 1. All parameters NOT specially mentioned are measured at 230VAC input, rated load and 25°C of ambient temperature. 2. Ripple & noise are measured at 20MHz of bandwidth by using a 12" twisted pair-wire terminated with a 0.1uf & 47uf parallel capacitor. 3. Tolerance : includes set up tolerance, line regulation and load regulation. 4. The power supply is considered a component which will be installed into a final equipment. The final equipment must be re-confirmed that it still meets EMC directives. For guidance on how to perform these EMC tests, please refer to "EMI testing of component power supplies." (as available on http://www.meanwell.com) 5. Can't use the PWM signal to control the output voltage. 			



3000W Single Output Power Supply

RSP-3000 series

Mechanical Specification

Case No.982B Unit:mm

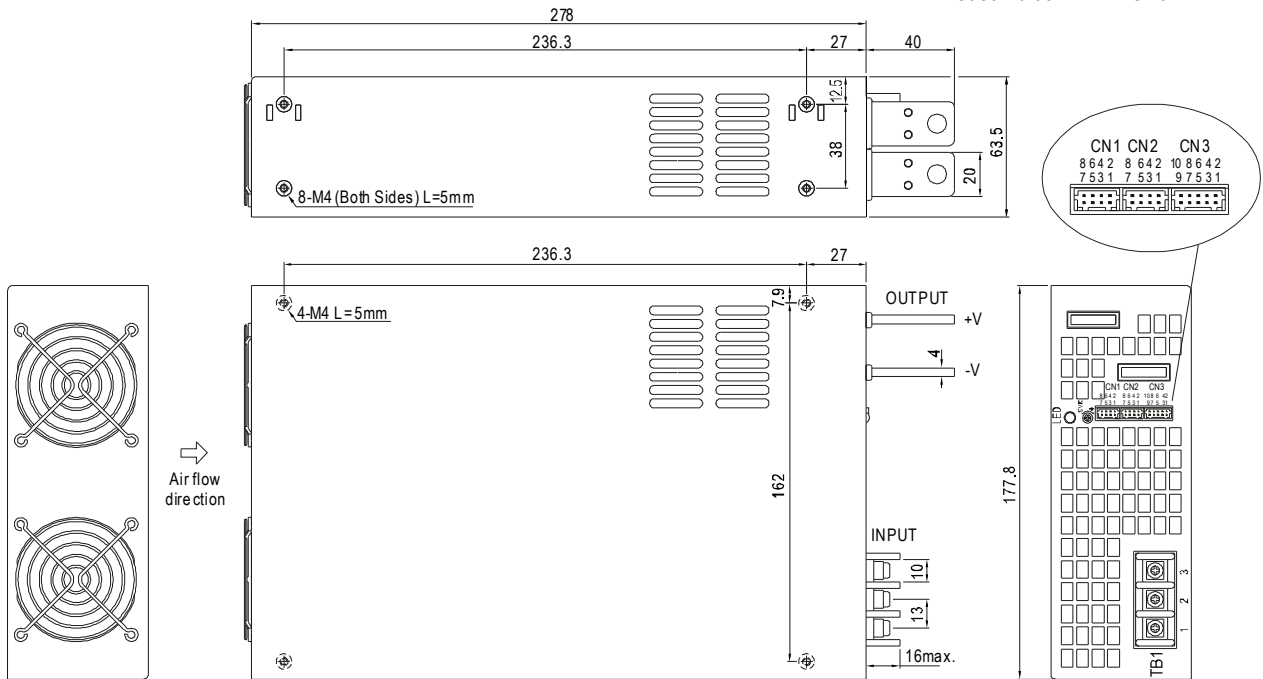

AC Input Terminal Pin No. Assignment

Pin No.	Assignment
1	AC/L
2	AC/N
3	FG \perp

Control Pin No. Assignment(CN1, CN2) : HRS DF 11-8DP-2DS or equivalent

Pin No.	Assignment	Pin No.	Assignment	Mating Housing	Terminal
1	RCG	5,7	-S	HRS DF11-8DS or equivalent	HRS DF11-**SC or equivalent
2	RC	6	CS(Current Share)		
3	PV	8	+S		
4	PS				

RCG: Remote ON/OFF Ground -S: -Remote Sensing
 RC : Remote ON/OFF CS: Load Share
 PV :Output Voltage External Control +S: +Remote Sensing
 PS : Reference Voltage Terminal

Control Pin No. Assignment(CN3) : HRS DF11-10DP-2DS or equivalent

Pin No.	Assignment	Pin No.	Assignment	Pin No.	Assignment	Pin No.	Assignment	Mating Housing	Terminal
1	P OK GND	4	P OK2	7	AUXG	10	OL-SD	HRS DF11-10DS or equivalent	HRS DF11-**SC or equivalent
2	P OK	5	RCG	8	AUX				
3	P OK GND2	6	RC	9	OLP				

P OK GND: Power OK Ground RCG: Remote ON/OFF Ground AUX: Auxiliary Output
 P OK: Power OK Signal (Relay Contact) RC: Remote ON/OFF OLP: OLP/OL-SD:OLP mode select
 P OK2: Power OK Signal (TTL Signal) AUXG: Auxiliary Ground

Block Diagram

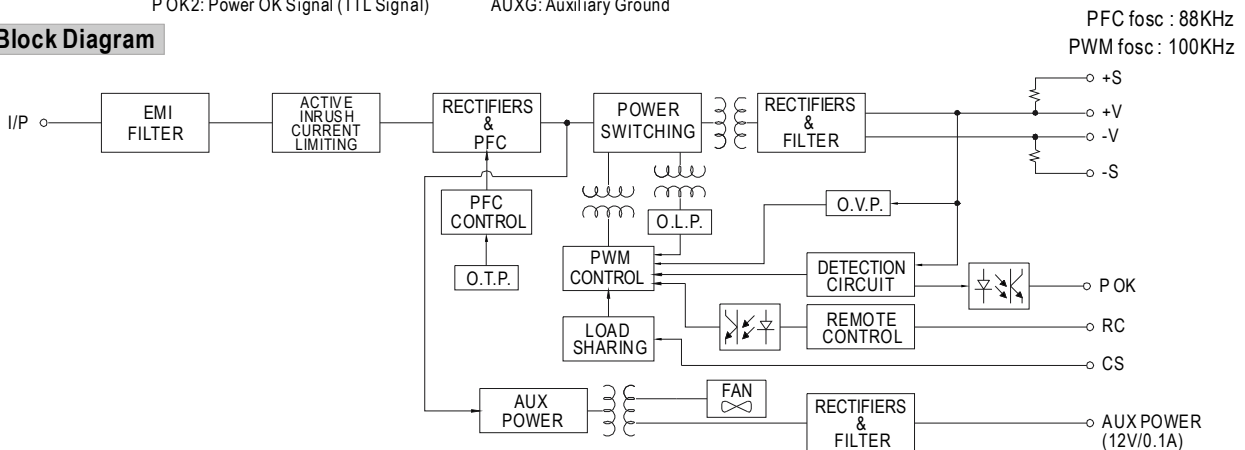



Derating Curve

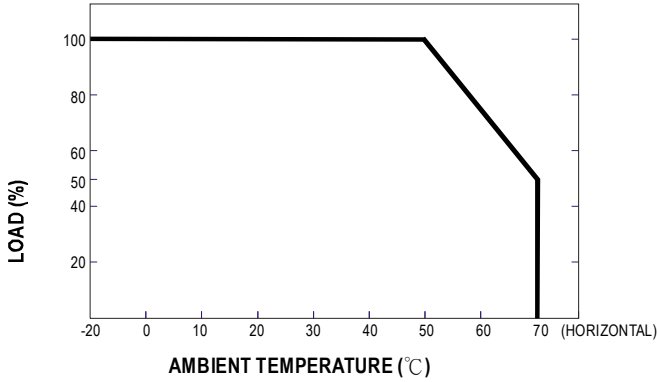

Static Characteristics

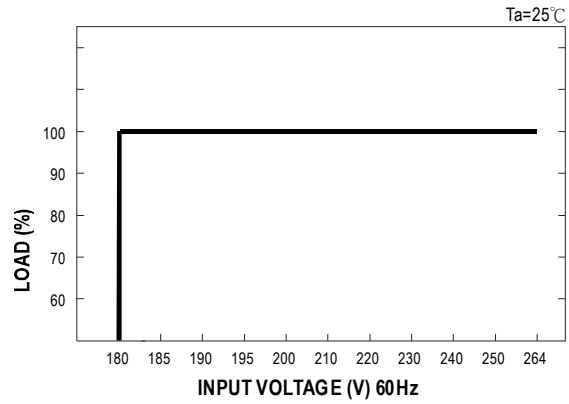

Function Manual

1. Remote ON/OFF

- (1) Remote ON/OFF control becomes available by applying voltage in CN1 & CN2 & CN3.
- (2) Table 1.1 shows the specification of Remote ON/OFF function.
- (3) Fig. 1.2 shows the example to connect Remote ON/OFF control function.

Table 1.1 Specification of Remote ON/OFF

Connection Method	Fig. 1.2(A)	Fig. 1.2(B)	Fig. 1.2(C)
SW Logic	Output on	SW Open	SW Close
	Output off	SW Close	SW Open

Fig.1.2 Examples of connecting remote ON/OFF

(A) Using external voltage source

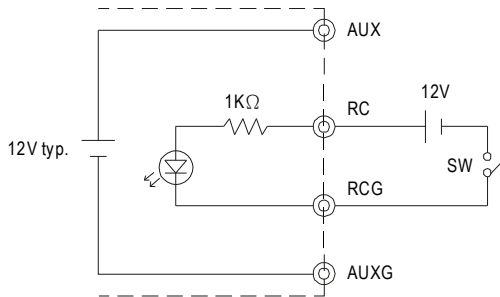

(B) Using internal 12V auxiliary output

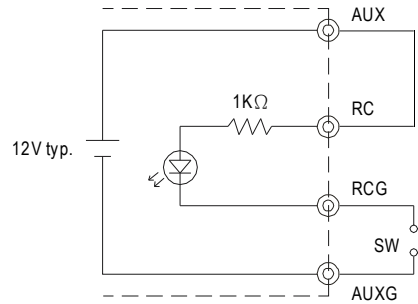

(C) Using internal 12V auxiliary output

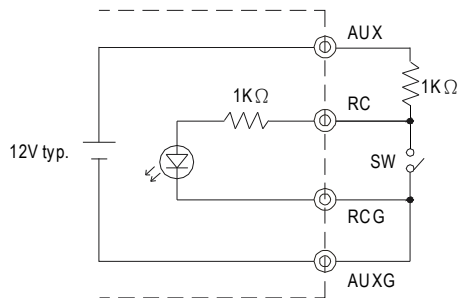



2. Alarm Signal Output

- (1) Alarm signal is sent out through "P OK" & "P OK GND" and P OK2 & P OK GND2 pins.
- (2) An external voltage source is required for this function.
- (3) Table 2.1 explain the alarm function built-in the power supply.

Function	Description	Output of alarm(P OK, Relay Contact)	Output of alarm(P OK2, TTL Signal)
P OK	The signal is "Low" when the power supply is above 80% of the rated output voltage-Power OK	Low (0.5V max at 500mA)	Low (0.5V max at 10mA)
	The signal turns to be "High" when the power supply is under 80% of the rated output voltage-Power Fail	High or open (External applied voltage, 500mA max.)	High or open (External applied voltage, 10mA max.)

Table 2.1 Explanation of alarm

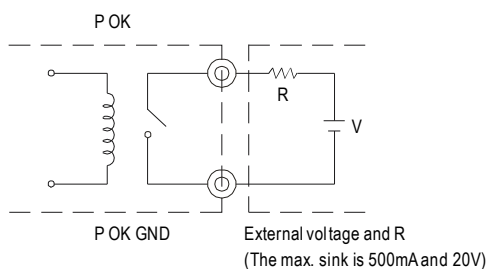

Fig. 2.2 Internal circuit of P OK (Relay, total is 10W)

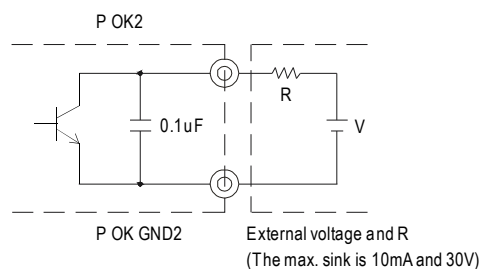

Fig. 2.3 Internal circuit of P OK2 (Open collector method)

3. Output Voltage TRIM

- (1) Connecting an external DC source between PV & -S on CN1 or CN2, and +S & +V, -S & -V also need to be connected that is shown in Fig. 3.1.
- (2) Adjustment of output voltage is possible between 20~110%(Typ.) of the rated output which is shown in Fig. 3.2. Reducing output current is required when the output voltage is trimmed up.

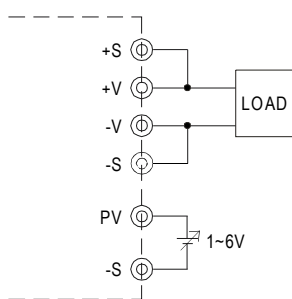

Fig. 3.1 Add on 1-6V external voltage

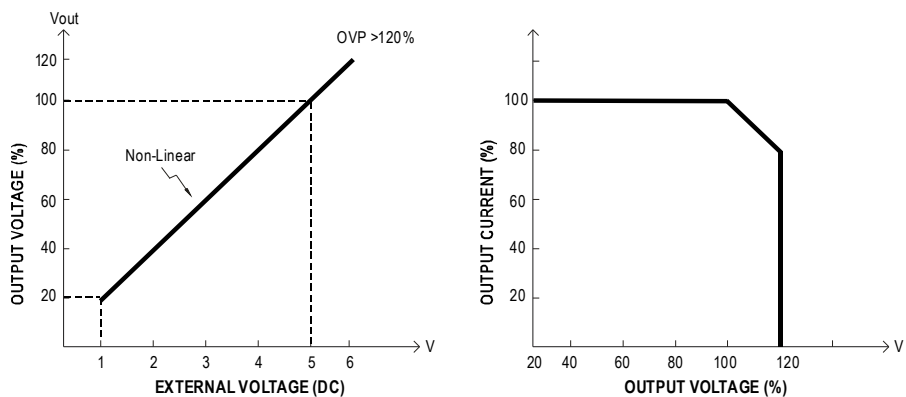
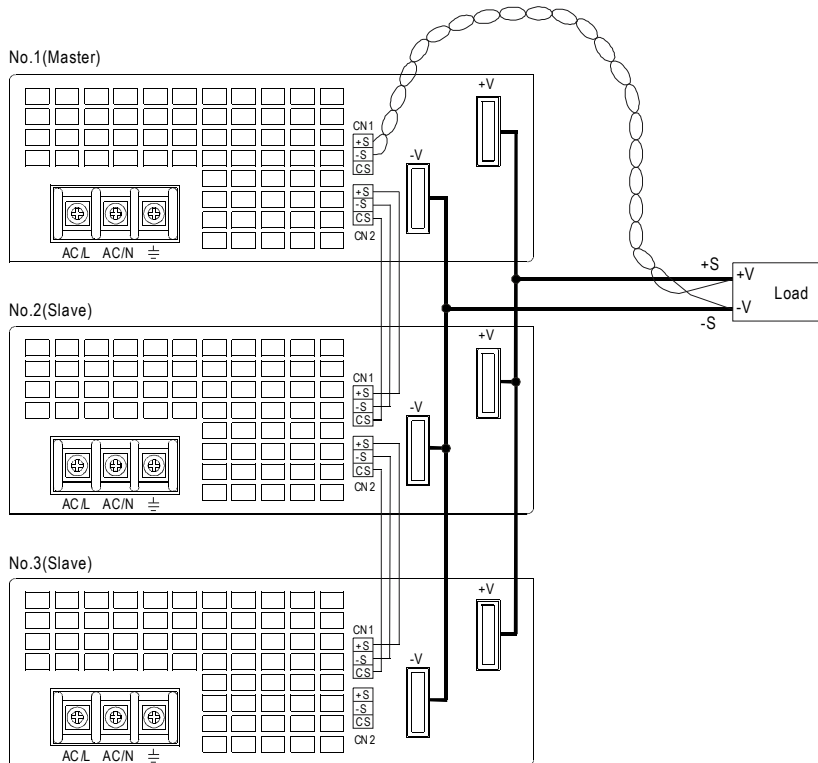

Fig. 3.2 Output voltage trimming



4. Current Sharing

- (1) Parallel operation is available by connecting the units shown as below (+S, -S and CS are connected mutually in parallel):
- (2) The voltage difference among each output should be minimized that less than 0.2V is required.
- (3) The total output current must not exceed the value determined by the following equation.
(Output current at parallel operation) = (The rated current per unit) x (Number of unit) x 0.9
- (4) In parallel operation 3 units is the maximum, please consult the manufacturer for other applications.
- (5) When remote sensing is used in parallel operation, the sensing wire must be connected only to the master unit.
- (6) Wires of remote sensing should be kept at least 10 cm from input wires.



- (7) When in parallel operation, the minimum output load should be greater than 3% of total output load.
(Min. Load > 3% rated current per unit x number of unit)
- (8) Under parallel operation, the "output voltage trim" function is not available.

5. Select O.L.P mode

- (1) Remove the shorting connector on CN3 that is shown in Fig 5.1, the O.L.P. mode will be "continuous constant current limiting".
- (2) Insert the shorting connector on CN3 that is shown in Fig 5.2, the O.L.P. mode will be "constant current limiting with delay shutdown after 5 seconds, re-power on to recover".

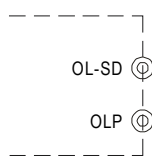

Fig. 5.1 Remove the CN3
OLP Mode : constant current limiting

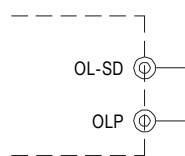
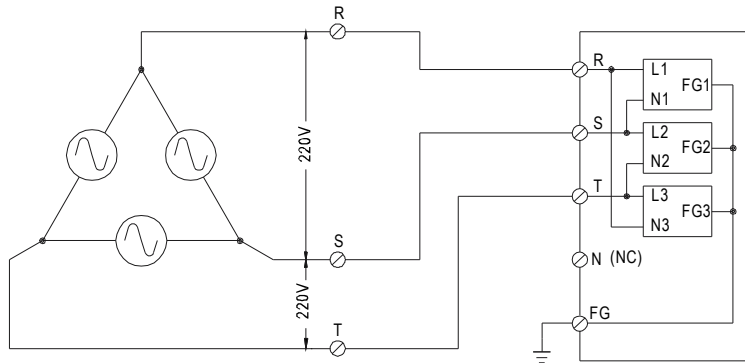

Fig. 5.2 Insert the CN3
OLP Mode : constant current limiting with delay shutdown after 5 seconds



6. Three Phase Connect

■ FIG. A: 3 ϕ 3W 220VAC SYSTEM (STANDARD MODEL FOR STOCK)



■ FIG. B: 3 ϕ 4W 220/380VAC SYSTEM

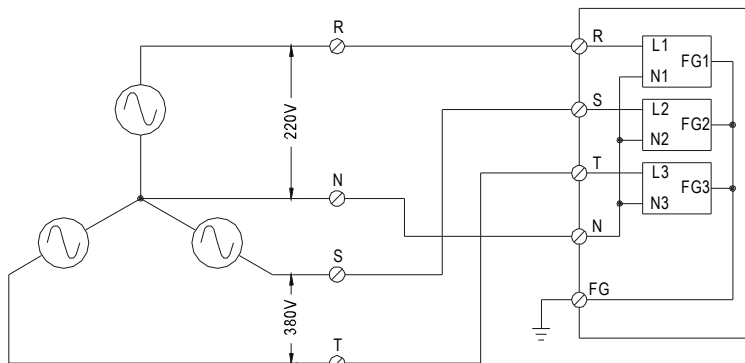

■ FIG. C: 3 ϕ 4W 190/110VAC SYSTEM

